



2000 Advanced Placement Program® Free-Response Questions

The materials included in these files are intended for use by AP® teachers for course and exam preparation in the classroom; permission for any other use must be sought from the Advanced Placement Program. Teachers may reproduce them, in whole or in part, in limited quantities, for face-to-face teaching purposes but may not mass distribute the materials, electronically or otherwise. These materials and any copies made of them may not be resold, and the copyright notices must be retained as they appear here. This permission does not apply to any third-party copyrights contained herein.

These materials were produced by Educational Testing Service (ETS), which develops and administers the examinations of the Advanced Placement Program for the College Board. The College Board and Educational Testing Service (ETS) are dedicated to the principle of equal opportunity, and their programs, services, and employment policies are guided by that principle.

The College Board is a national nonprofit membership association dedicated to preparing, inspiring, and connecting students to college and opportunity. Founded in 1900, the association is composed of more than 3,800 schools, colleges, universities, and other educational organizations. Each year, the College Board serves over three million students and their parents, 22,000 high schools, and 5,000 colleges, through major programs and services in college admission, guidance, assessment, financial aid, enrollment, and teaching and learning. Among its best-known programs are the SAT®, the PSAT/NMSQT®, the Advanced Placement Program® (AP®), and Pacesetter®. The College Board is committed to the principles of equity and excellence, and that commitment is embodied in all of its programs, services, activities, and concerns.

Copyright © 2000 by College Entrance Examination Board and Educational Testing Service. All rights reserved. College Board, Advanced Placement Program, AP, and the acorn logo are registered trademarks of the College Entrance Examination Board.



E E E E E E E E E E E E E E E E E E

2000 AP[®] PHYSICS C FREE-RESPONSE QUESTIONS

PHYSICS C

Section II, ELECTRICITY AND MAGNETISM

Time—45 minutes

3 Questions

Directions: Answer all three questions. The suggested time is about 15 minutes for answering each of the questions, which are worth 15 points each. The parts within a question may not have equal weight. Show all your work in the pink booklet in the spaces provided after each part, NOT in this green insert.

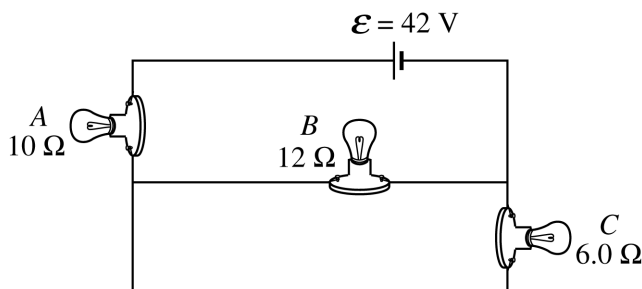

E & M 1.

Lightbulbs *A*, *B*, and *C* are connected in the circuit shown above.

- (a) List the bulbs in order of their brightness, from brightest to least bright. If any bulbs have the same brightness, state which ones. Justify your answer.

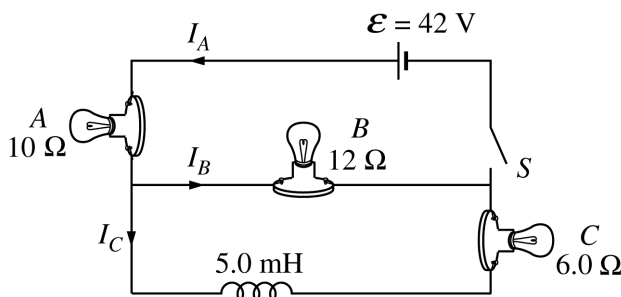

Now a switch *S* and a 5.0 mH inductor are added to the circuit, as shown above. The switch is closed at time $t = 0$.

- (b) Determine the currents I_A , I_B , and I_C for the following times.
- i. Immediately after the switch is closed
 - ii. A long time after the switch is closed

E E E E E E E E E E E E E E E E E

2000 AP[®] PHYSICS C FREE-RESPONSE QUESTIONS

- (c) On the axes below, sketch the magnitude of the potential difference V_L across the inductor as a function of time, from immediately after the switch is closed until a long time after the switch is closed.

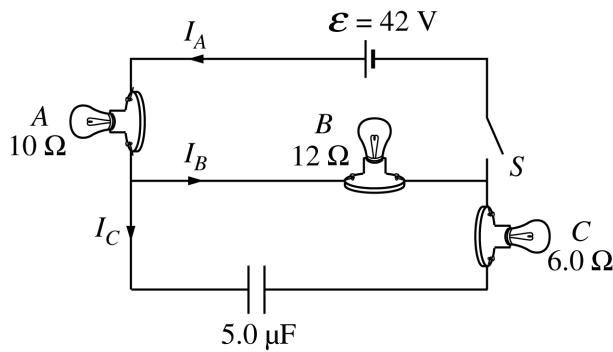

- (d) Now consider a similar circuit with an uncharged $5.0 \mu\text{F}$ capacitor instead of the inductor, as shown above. The switch is again closed at time $t = 0$. On the axes below, sketch the magnitude of the potential difference V_{cap} across the capacitor as a function of time, from immediately after the switch is closed until a long time after the switch is closed.



2000 AP[®] PHYSICS C FREE-RESPONSE QUESTIONS

E & M 2.

Three particles, A , B , and C , have equal positive charges Q and are held in place at the vertices of an equilateral triangle with sides of length ℓ , as shown in the figures below. The dotted lines represent the bisectors for each side. The base of the triangle lies on the x -axis, and the altitude of the triangle lies on the y -axis.

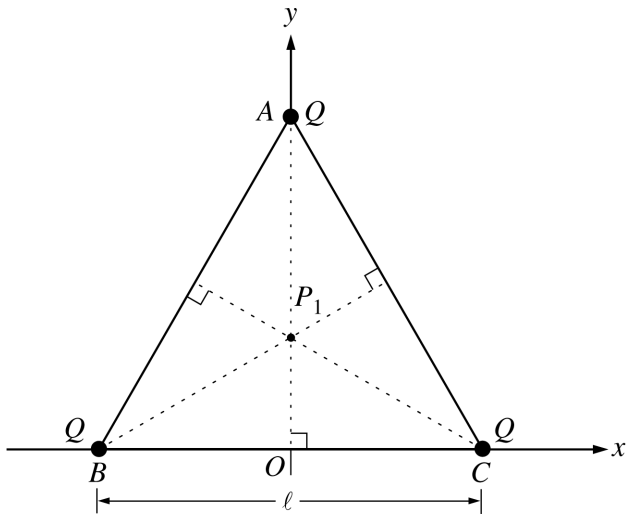

Figure 1

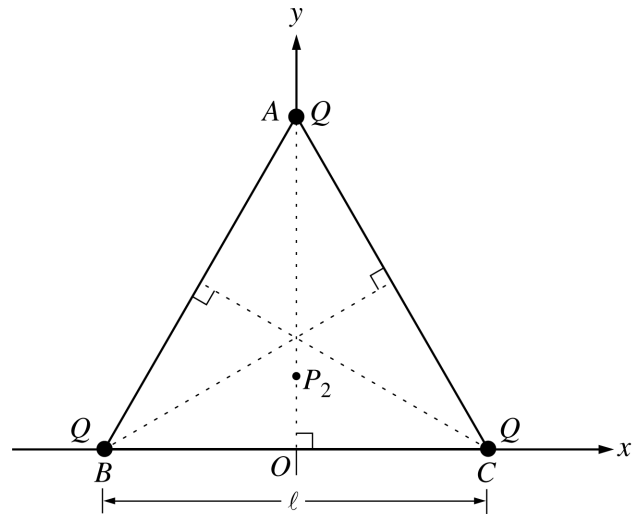

Figure 2

(a)

- i. Point P_1 , the intersection of the three bisectors, locates the geometric center of the triangle and is one point where the electric field is zero. On Figure 1 above, draw the electric field vectors \mathbf{E}_A , \mathbf{E}_B , and \mathbf{E}_C at P_1 due to each of the three charges. Be sure your arrows are drawn to reflect the relative magnitude of the fields.
- ii. Another point where the electric field is zero is point P_2 at $(0, y_2)$. On Figure 2 above, draw electric field vectors \mathbf{E}_A , \mathbf{E}_B , and \mathbf{E}_C at P_2 due to each of the three point charges. Indicate below whether the magnitude of each of these vectors is greater than, less than, or the same as for point P_1 .

	Greater than at P_1	Less than at P_1	The same as at P_1
E_A			
E_B			
E_C			

2000 AP[®] PHYSICS C FREE-RESPONSE QUESTIONS

- (b) Explain why the x -component of the total electric field is zero at any point on the y -axis.
- (c) Write a general expression for the electric potential V at any point on the y -axis inside the triangle in terms of Q , ℓ , and y .
- (d) Describe how the answer to part (c) could be used to determine the y -coordinates of points P_1 and P_2 at which the electric field is zero. (You do not need to actually determine these coordinates.)

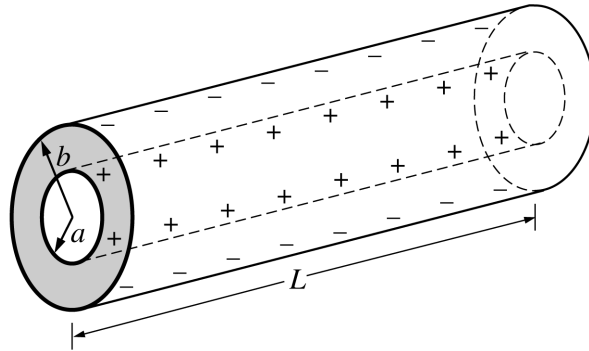

E & M 3.

A capacitor consists of two conducting, coaxial, cylindrical shells of radius a and b , respectively, and length $L \gg b$. The space between the cylinders is filled with oil that has a dielectric constant κ . Initially both cylinders are uncharged, but then a battery is used to charge the capacitor, leaving a charge $+Q$ on the inner cylinder and $-Q$ on the outer cylinder, as shown above. Let r be the radial distance from the axis of the capacitor.

- (a) Using Gauss's law, determine the electric field midway along the length of the cylinder for the following values of r , in terms of the given quantities and fundamental constants. Assume end effects are negligible.
 - i. $a < r < b$
 - ii. $b < r \ll L$
- (b) Determine the following in terms of the given quantities and fundamental constants.
 - i. The potential difference across the capacitor
 - ii. The capacitance of this capacitor

2000 AP[®] PHYSICS C FREE-RESPONSE QUESTIONS

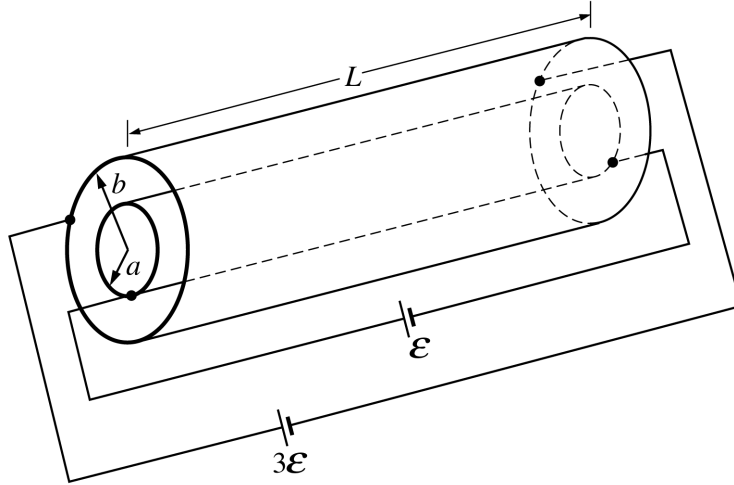

- (c) Now the capacitor is discharged and the oil is drained from it. As shown above, a battery of emf \mathcal{E} is connected to opposite ends of the inner cylinder and a battery of emf $3\mathcal{E}$ is connected to opposite ends of the outer cylinder. Each cylinder has resistance R . Assume that end effects and the contributions to the magnetic field from the wires are negligible. Using Ampere's law, determine the magnitude B of the magnetic field midway along the length of the cylinders due to the current in the cylinders for the following values of r .
- $a < r < b$
 - $b < r \ll L$

S T O P

END OF SECTION II, ELECTRICITY AND MAGNETISM

IF YOU FINISH BEFORE TIME IS CALLED, YOU MAY CHECK YOUR WORK ON SECTION II, ELECTRICITY AND MAGNETISM, ONLY. DO NOT TURN TO ANY OTHER TEST MATERIALS.